

AM8

8 CHANNEL AUTOMATIC MIXER

OPERATING INSTRUCTIONS and trouble-shooting guide

LECTROSONICS, INC.

Rio Rancho, NM

U.S. Patent Number: 5,414,776 and 5,402,500

INTRODUCTION

The AM8 Automatic Microphone Mixer is an 8 channel, single rack space audio mixer. Using Lectrosonics' unique Adaptive Level Proportional mixing algorithm, the automatic action is inaudible and simple to set up. The AM8 offers remote control of all channel levels and the master level. In addition, a sophisticated compressor/leveller is included for dynamic range control of the audio program material. The AM8 has an RS-232 port for remote setup or control by a computer or other RS-232 compatible controller. More than one AM8 may be coupled together when applications call for more than 8 channels.

TABLE OF CONTENTS

INTRODUCTION	2
GENERAL TECHNICAL DESCRIPTION	3
INSTALLATION	4
FRONT PANEL DESCRIPTION	5
REAR PANEL DESCRIPTION	6
FCC PART 15 NOTICE	7
OPERATING INSTRUCTIONS	8
REMOTE LEVEL CONNECTIONS	9
TROUBLESHOOTING	9
SERVICE AND REPAIR	10
RETURNING UNITS FOR REPAIR	10
SPECIFICATIONS	11
SERIAL CABLE WIRING DIAGRAM	12
AMX CABLE WIRING DIAGRAM	12
AMX Programming Notes	12
SERIAL PORT COMMANDS AVAILABLE	13
WARRANTY	Back cover

GENERAL TECHNICAL DESCRIPTION

The AM8 uses a straightforward analog signal path to provide excellent audio performance. This is coupled with a sophisticated microcontroller to implement both the automatic mixing and the compressor/leveller algorithms. The Adaptive Level Proportional automatic mixing algorithm is used by the AM8. This algorithm uses the signal level pattern at the microphones to derive a pattern of channel gains. For instance, if only one microphone channel is being spoken into, its level is dominant and that channel gets most of the system gain, while all other channels are turned down. If more than one microphone is active, they share system gain according to their relative levels. A "skewing" function gives some advantage to microphones which are active over time, to minimize interruptions from transient noise at other microphones. Since each channels' gain is apportioned continuously based on its relative level, no abrupt gain changes are made. This makes the automatic action virtually inaudible.

The Compressor/Leveller function uses a combination of the short-term and long-term signal dynamics to determine the optimum amount of gain reduction in any situation. The effect of the function is to control both the average program level (for consistent long-term sound system level) and to minimize any large short-term deviations. The gain reduction function is gated, which means that there are no noise ups associated with program signal pauses.

Figure 1 shows the simplified block diagram of the AM8. The microphone preamp is a low-noise discrete design, which is extensively RF protected. The preamp has three gain settings. The 0dB setting allows an input to accept line level signals, while the +30dB and +50dB gain settings accommodate both low and high sensitivity microphones. 15V Phantom power is provided for each channel, and is switchable. In addition, each channel may be switched into either the Direct (always on) or Auto mode.

Following the Channel Level control, the audio signal passes through a high quality Voltage Controlled Amplifier (VCA). This VCA, controlled by a signal from the system D/A converter, is used to implement gain control for the automatic mixing function, as well as the remote level function. A Channel On LED indicates which channels are currently active.

Signals from the Expansion In and Expansion Out connectors allow multiple AM8 mixers to be combined if more than 8 channels are necessary for the application. In addition, a Mix Minus signal is available which allows easy interfacing to teleconferencing hybrids.

An RS-232 port is available to allow many of the functions of the AM8 to be controlled either by a computer or a dedicated control system (such as the AMX or Crestron systems).

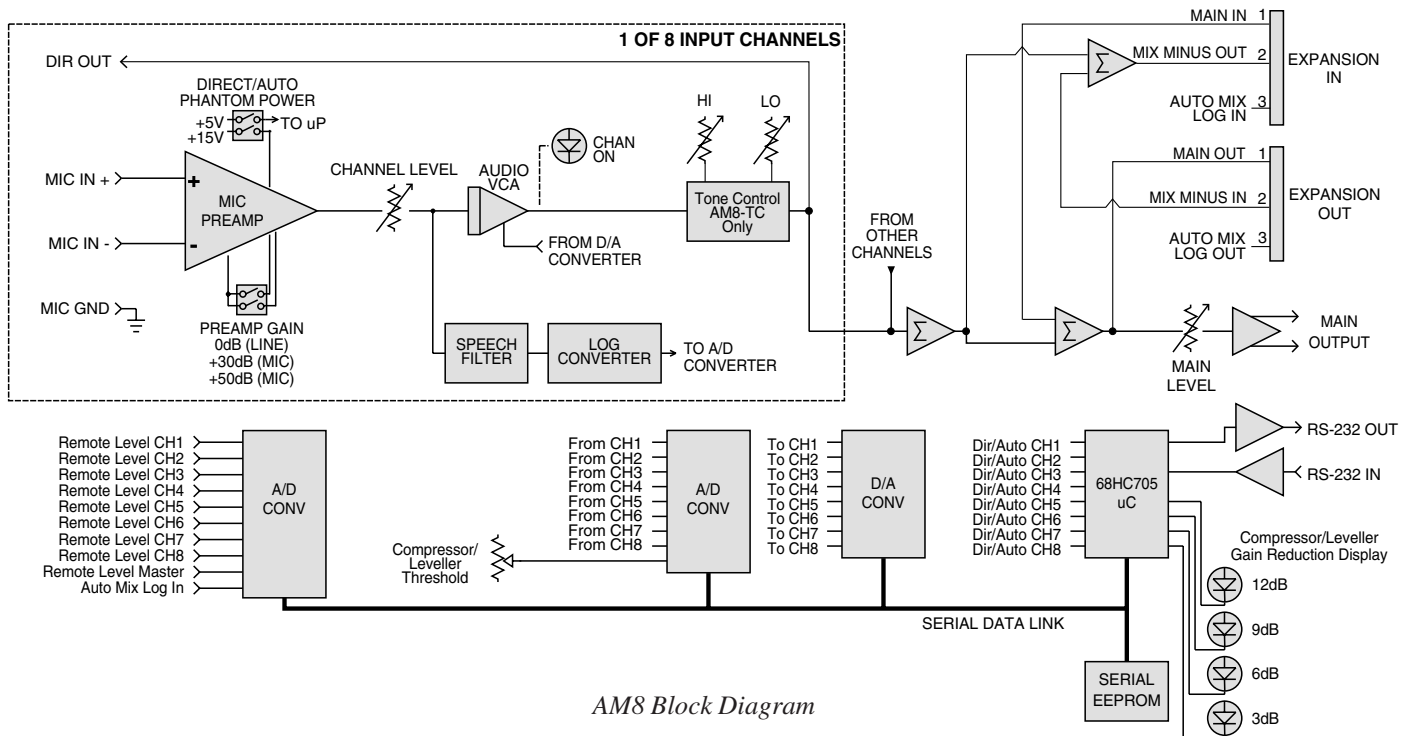

INSTALLATION

Installing the AM8 properly is simple, and only requires attention to a few issues. The AM8 should be used in a grounded metal rack. If only one AM8 is being used, it should be placed in the Master mode, using the rear panel switch. Erratic performance will result if the unit is in the Slave mode, but no damage will be done to the unit. Proper operation will be restored when the unit is switched to the Master mode. If multiple AM8s are used together, the first AM8 (i.e. the one with Expansion In port used but not the Expansion Out port) should be switched to the Master mode, while all other AM8s should be in the Slave mode. Figure 2 shows the correct interconnection for multiple AM8s.

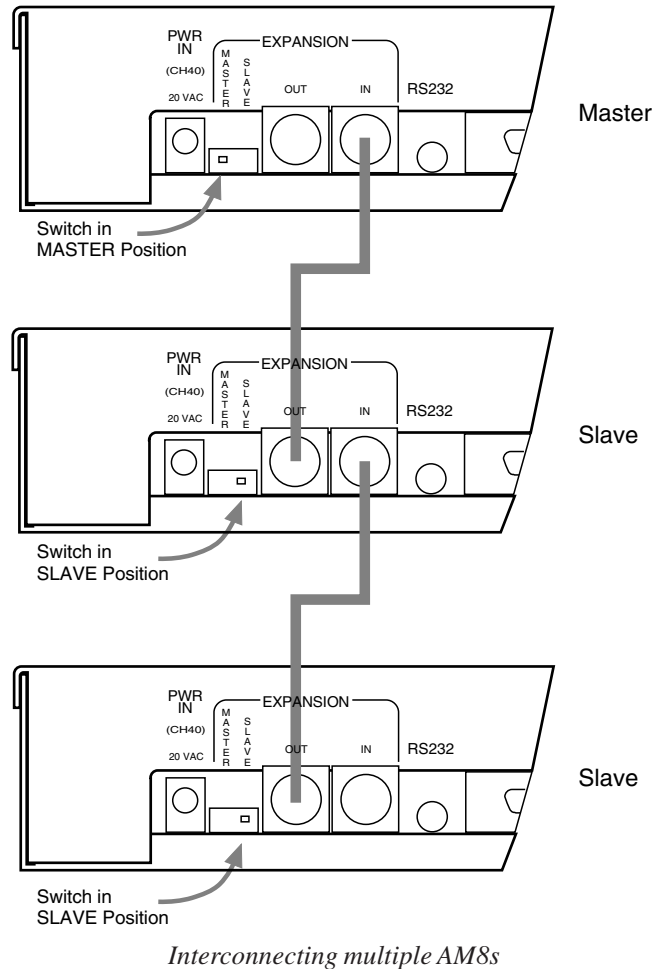

Microphone connections should be made with good quality braid or foil shielded twisted pair. The shield should be used for the ground (Pin 1) connection. If an unbalanced signal is used, the unbalanced signal lead should be connected to the “+” input terminal, while the unbalanced ground lead should be connected to both the “-” and ground terminals of the input connector.

Output connections to the Main Out connector can be made balanced or unbalanced. If an unbalanced connection is desired, simply connect the unbalanced signal lead to the “+” output terminal, and the unbalanced ground lead to the output ground terminal. Leave the “-” output terminal unconnected.

Access to the Remote Level Control port is accomplished using the DB-15 connector (supplied).

FRONT PANEL DESCRIPTION

CHANNEL SECTION

CHANNEL LEVEL - Controls the relative signal level of each channel. Normal operation of the Channel Level control is from about the 10 o'clock position to the 2 o'clock position.

CHANNEL ON LED - Gives an indication as to which channels are active.

LF - (TC version only) Adjusts the low frequency response of the channel.

HF - (TC version only) Adjusts the high frequency response of the channel.

MAIN SECTION

MAIN LEVEL - Controls the overall output level of the AM8. If multiple AM8s are used together, only the Main Level control of the last (i.e. Master) AM8 will be operational.

COMPRESSOR/LEVELLER IN/OUT - Enables or disables the compressor/leveller function.

COMPRESSOR/LEVELLER THRESHOLD - Sets the signal level above which the Compressor/leveller is active. Note that the Threshold level is measured before the Main Level control. This means that adjustments of the Main Level control will not affect the amount of gain reduction.

COMPRESSOR/LEVELLER GAIN REDUCTION METER - Shows the instantaneous amount of gain reduction applied by the compressor/leveller system.

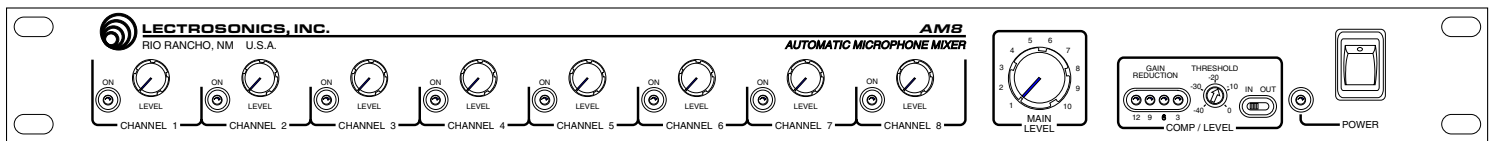

AM8 Front Panel

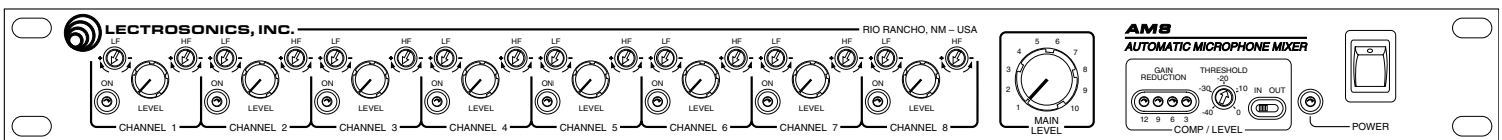

AM8TC Front Panel

REAR PANEL DESCRIPTION

MIC/LINE INPUTS 1-8 - Accepts balanced or unbalanced signal. Fully balanced differential input, RF filtered.

DIR OUT - Provides a line level signal from each individual channel. The direct output is a post-VCA signal. Any attenuation from the auto mixing process, compressor/leveler system or remote attenuation will be reflected in the direct out signal. This provides versatility for different mixing applications such as distributed overhead speaker systems. This 100 Ohm output provides a +20dBu max signal into a high impedance load.

Note: The DIR OUT shares a ground with the MAIN OUT.

--Don't use the CHANNEL IN grounds for the DIR OUT!--

When connecting to other equipment, the ground connection of the MAIN OUT will also be adequate for all the direct outputs. A separate ground connection is not needed for each direct out.

FUNCTION SELECTION SWITCHES 1-8 - Allow various functions of the input channels to be set.

Dip switch 1 chooses the channel mode. Auto mode (down position) sets operation to automatic, with channel gain determined by its signal level relative to other microphones. When a channel is set to Direct, its signal will affect the levels of other channels set to Auto, but it will not be affected by other channels (no NOM attenuation will occur on a channel set to Direct). Note, however, that the Remote Level control feature functions regardless of the setting of the Auto/Direct mode switch.

Dip switch 2 turns +15V phantom power on (down position) or off (up position).

Dip switches 3 and 4 set the gain of the input preamplifier. 0dB gain, for line level sources, is set when switches 3 and 4 are in the up position. 30dB gain, typically for high output (electret) microphones, is set when switch 3 is in the up position and switch 4 is in the down position. 50dB gain, used for low output (dynamic) microphones, is set when both switches are in the down position.

MAIN OUT - Provides a balanced system output. The Main Out may also be used in an unbalanced mode by connecting the "+" terminal of the Main Out to the signal lead of the unbalanced device, and the ground terminal of the Main Out to the ground of the unbalanced device. Do not connect the "-" terminal of the Main Out.

REMOTE LEVEL CONTROL - Allows remote control of both channel levels and the master level. Either 10K ohm linear pots or an adjustable DC control voltage may be used. The volume control action is internally audio scaled in software. This gives an "audio-taper" characteristic to a linear pot. Approximately 15dB of attenuation happens for the first half of pot rotation, with the rest of the attenuation (to full off) happening in the second half of pot rotation. When using a DC control voltage, the control constant is .167V/dB (or 6dB/V) from 0V to 5V. At 5V, the channel is turned completely off. The control voltage should not exceed 5V. Below is a listing of the 15 pins on the Remote Level control port and their functions.

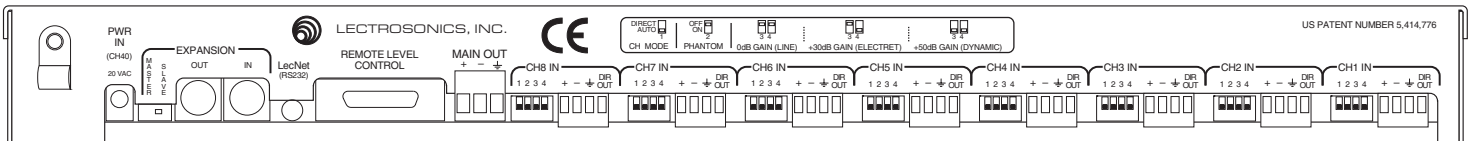

AM8 Rear Panel

REMOTE LEVEL CONTROL CONNECTOR PINOUT

<u>Pin Number</u>	<u>Function</u>
1	Channel 1 Wiper
2	Channel 2 Wiper
3	Channel 3 Wiper
4	Channel 4 Wiper
5	Channel 5 Wiper
6	Channel 6 Wiper
7	Channel 7 Wiper
8	Channel 8 Wiper
9	Channel 1-8 CCW Connection (common to all channels, +5V)
10	Channel 1-8 CW Connection (common to all channels, ground)
11	Main CW Connection (ground)
12	Main Wiper Connection
13	Main CCW Connection (+5V)
14	Not Used
15	Reset to Local Mode (see Operating Instructions)

RS-232 SERIAL PORT - Provides access to and control of some of the operational features of the AM8. The port is compatible with the serial port of a PC, or other controllers with RS-232 type serial ports. For hardware interconnection and software details, see Appendix 1, "Serial Port Hardware and Software".

EXPANSION IN/OUT - Allow multiple AM8s to be used together. If more than one AM8 are used together, the first AM8 (i.e. the one with Expansion In port used but not the Expansion Out port) should be switched to the Master mode, while all other AM8s should be in the Slave mode. The Expansion Out of the second AM8 is connected to the Expansion In of the first AM8, using the supplied cable.

*LecNet Expansion
In/Out Ports*

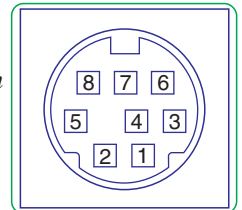

MASTER/SLAVE SWITCH - Sets the AM8 for use as a Master device or a Slave device. AM8s used singly should be set for Master mode operation.

PWR IN - Connects to the CH40 power supply to provide power for the AM8.

FCC PART 15 NOTICE

This equipment has been tested and found to comply with the limits for a class B digital device, pursuant to Part 15 of the FCC Rules. These limits are designed to provide reasonable protection against harmful interference in a residential installation. This equipment generates, uses and can radiate radio frequency energy and, if not installed and used in accordance with the instructions, may cause harmful interference to radio communications. If this equipment does cause harmful interference to radio or television reception, which can be determined by turning the equipment off and on, the user is encouraged to try to correct the interference by one or more of the following measures:

- Reorient or relocate the receiving antenna.
- Increase the separation between the equipment and receiver.
- Connect the equipment into an outlet on a circuit different from that to which the receiver is connected.
- Consult the dealer or an experienced radio/TV technician for help.

OPERATING INSTRUCTIONS

Setup of the AM8 consists of choosing rear panel dip switch options, setting front panel levels, and adjusting the compressor/leveller (if used). Using the Remote Level Control capability of the AM8 is addressed in the next section. When the power is turned on to the AM8, it will display its LecNet address on the Channel On LEDs for 1.5 seconds before entering normal operation. Channel 8 On LED represents the most significant bit of the binary address, while Channel 1 On LED represents the least significant bit.

- 1) Select Auto or Direct mode using dip switch 1 on channels 1-8. Normally, all speech microphones would be in the Auto mode. Microphones used for music (e.g. choir mics in a church sound system), or inputs attached to line level devices like tape players or VCRs are best used in the Direct mode. The Remote Level Control terminals may be used to manually turn off Direct mode microphones when they are not in use.
- 2) Turn Phantom power on or off as needed, using dip switch 2 on channels 1-8. Dynamic microphones need no phantom power, but electret types will need phantom power to operate properly.
- 3) Set up the preamplifier gain using dip switches 3 and 4 on channels 1-8. The 0dB position is used for line level sources like tape players or VCRs. The 30dB position works well for higher output microphones like electrets. The 50dB position is best for dynamic microphones, or electret types where the distance from the talker to the microphone is more than 3 feet or so.
- 4) Set the Main Level control between 5 and 6. While speaking into each microphone in turn, adjust the Channel Level to give adequate volume level. The normal operating position of the Channel Level control should be between 10 o'clock and 2 o'clock. Try to adjust all microphones to about the same volume level, as this will result in the most optimum automatic action.
- 5) If the compressor/leveller system is to be used, switch the In/Out front panel switch to the In position. With a normal talker, adjust the Threshold pot until the 3dB Gain Reduction LED flickers on. The system volume level may need to be readjusted at this point using the Main Level control. Next, check that a loud talker turns on most or all of the remaining Gain Reduction LEDs. Finally, with a soft talker such that no Gain Reduction LEDs are lit, be sure there is no feedback or ringing in the system.

The system is now ready for use.

Note: Be sure to set the AM8 back to "Local" mode after using the software-based control panel on a PC. If the unit was left in "Remote" mode and there is no PC available, it will be necessary to perform a "Reset to Local" procedure.

1. Turn off the power to the AM8.
2. Short Pin 10 to pin 15 on the rear panel DB15 connector while turning on the power switch.
3. Remove the short from pins 10 and 15.

All subsystems are now in "Local" mode and controllable from the AM8 front/rear panel.

There are three subsystems that can be effectively disabled if they are left in "Remote" mode:

1. The Compressor/Leveller subsystem. If this function is in "Remote", the symptoms will be no response from the Threshold control and the In/Out switch.
2. The Auto/Direct function. If this function is in "Remote," the AM8 will ignore the state of the rear panel dipswitches.
3. The Remote Level Control subsystem. If this function is in "Remote", there will be no response from the remote level control.

REMOTE LEVEL CONNECTIONS

The figure below shows several options which may be used for remote level control of the AM8. Pots, switches, and external control voltages may all be used as the application dictates.

WIRING DIAGRAMS, REMOTE LEVEL CONTROL PORT
(REMOTE LEVEL CONTROL PORT, 15 PIN D-SUB)

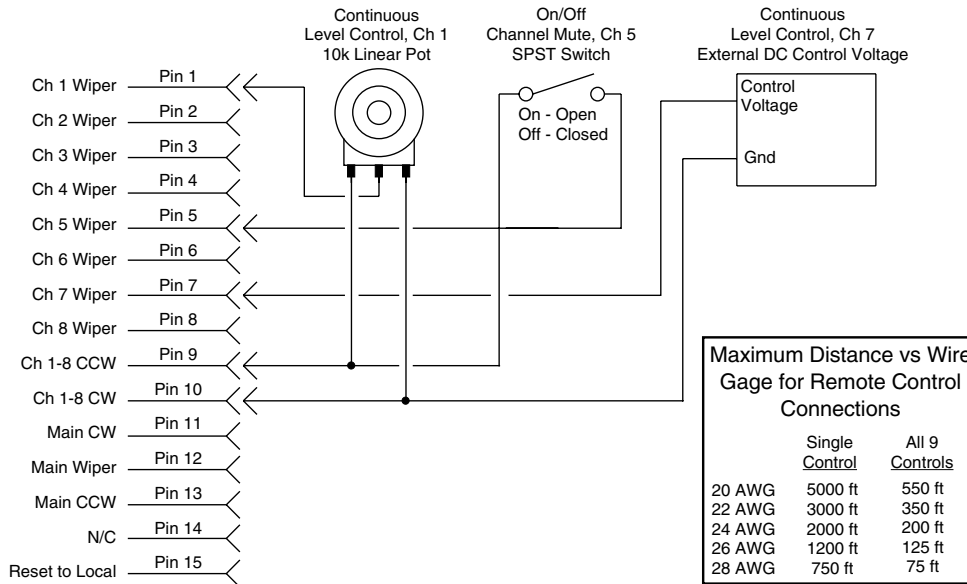

TROUBLESHOOTING

SYMPTOM

POSSIBLE CAUSE

No sound from system

- 1) Main level control not turned up
- 2) Channel level not turned up
- 3) Input gain setting too low
- 4) Phantom power not on for electret microphone
- 5) Remote level control turned down

Difficulty activating certain mics

- 1) Mic level is too low relative to other mics - Turn up the mic level

All front panel channel LEDs are on all the time, with or without signal applied.

- 1) If you are using just one AM8/AM8-TC, be sure the rear panel Master/Slave switch is in the Master mode.
- 2) Be sure that the Direct/Auto dip switch associated with each channel is in the Auto position. If changing these switches does not fix the problem, the AM8/AM8-TC might be in the Remote mode. It can be reset to the Local mode by turning the power off, shorting pins 10 and 15 together (located on the rear panel Remote Level Control connector), and turning the power back on while the pins are shorted.
- 3) If you are using more than one AM8/AM8-TC in your system, set the AM8/AM8-TC whose Expansion In (but not Expansion Out) port is used to Master mode, and all other AM8/AM8-TCs to Slave mode.

You can't control the channel and main gains from the rear panel Remote Level Control connector.

- 1) The AM8/AM8-TC might be in the Remote mode, in which case it will not respond to control voltages applied to the Remote Level Control pins. The AM8/AM8-TC can be reset to the Local mode by turning the power off, shorting pins 10 and 15 together (located on the rear panel Remote Level Control connector), and turning the power back on while the pins are shorted.

SERVICE AND REPAIR

If your system malfunctions, you should attempt to correct or isolate the trouble before concluding that the equipment needs repair. Make sure you have followed the setup procedure and operating instructions. Check out the interconnecting cords and then go through the TROUBLE SHOOTING section in the manual

We strongly recommend that you **do not** try to repair the equipment yourself and **do not** have the local repair shop attempt anything other than the simplest repair. If the repair is more complicated than a broken wire or loose connection, send the unit to the factory for repair and service. Don't attempt to adjust any controls inside the units. Once set at the factory, the various controls and trimmers do not drift with age or vibration and never require readjustment. **There are no adjustments inside that will make a malfunctioning unit start working.**

LECTROSONICS service department is equipped and staffed to quickly repair your equipment. In-warranty repairs are made at no charge in accordance with the terms of the warranty. Out of warranty repairs are charged at a modest flat rate plus parts and shipping. Since it takes almost as much time and effort to determine what is wrong as it does to make the repair, there is a charge for an exact quotation. We will be happy to quote approximate charges by phone for out of warranty repairs.

RETURNING UNITS FOR REPAIR

You will save yourself time and trouble if you will follow the steps below:

- A.** DO NOT return equipment to the factory for repair without first contacting us by letter or by phone. We need to know the nature of the problem, the model number and the serial number of the equipment. We also need a phone number where you can be reached 8 am to 4 pm (Mountain Standard Time).
- B.** After receiving your request, we will issue you a return authorization number (R.A.). This number will help speed your repair through our receiving and repair departments. The return authorization number must be clearly shown on the outside of the shipping container.
- C.** Pack the equipment carefully and ship to us, shipping costs prepaid. If necessary, we can provide you with the proper packing materials. UPS is usually the best way to ship the units. Heavy units should be "double-boxed" for safe transport.
- D.** We also strongly recommend that you insure the equipment, since we cannot be responsible for loss of or damage to equipment that you ship. Of course, we insure the equipment when we ship it back to you.

Mailing address:

Lectrosonics, Inc.
PO Box 15900
Rio Rancho, NM 87174
USA

Shipping address:

Lectrosonics, Inc.
581 Laser Rd.
Rio Rancho, NM 87124
USA

Telephones:

Regular: (505) 892-4501
Toll Free (800) 821-1121
FAX: (505) 892-6243

World Wide Web: <http://www.lectrosonics.com>

Email: sales@lectrosonics.com

SPECIFICATIONS

Mic/Line Input	
Type:	Electronically balanced and RF filtered
Impedance:	Greater than 2.5K, any gain setting
Input Gain Settings:	0dB, +30dB, +50dB
EIN, 20-20KHz:	-126dBu (+50dB gain)
Maximum Input Level:	+20dBu at 0dB gain -10dBu at +30dB gain -30dBu at +50dB gain
Tone Controls:	Shelving controls Turnover frequency 1kHz +/- 10dB at 100 Hz; +/- 10dB at 10 kHz
Main Out	
Impedance:	200 Ohms balanced; 100 Ohms unbalanced
Max output level:	+26dBu, 10k load
Direct Outputs	
Impedance:	100 Ohms, unbalanced
Max output level:	+20dBu, 10k load
Remote Level Control Range:	6dB/Volt from 0 to 5V, plus off
Serial Communication (RS-232):	9600 baud, 8 data bits, no parity, 1 stop bit
Compressor/Leveller	
Threshold:	-40dBu to 0dBu
Maximum Gain Reduction:	25dB (10dB leveling, 15dB compression)
Maximum System Gain	
Input to Main Out:	82dB
System THD: (+10dBu out)	Less than 0.1%, any gain setting
System IMD: (+10dBu out)	Less than 0.1%, any gain setting
Phantom Power:	+15V, switch selectable per channel
Power Consumption:	10 Watts max at 20VAC
Weight:	3 lbs, 4 ozs
Dimensions:	19"wide x 1.75"high x 8"deep

Specifications subject to change without notice.

This product meets the CE Compliance Standards - EN55022 and EN50082-1:1998. A copy of the Declaration of Conformity may be requested from your dealer or by contacting the factory directly:

Lectrosonics, Inc.
Marketing Department
581 Laser Rd. NE, Rio Rancho, NM 87124 USA
tel: 505-892-4501 fax: 505-892-6243 e-mail: marketing@lectrosonics.com

SERIAL CABLE WIRING DIAGRAMS

The serial port on the AM8/4 is a minimal RS-232 implementation. The figure shows the wiring diagram to accommodate interconnection with either a 9 or a 25 pin serial port on a PC or other serial device.

LecNet Device to PC

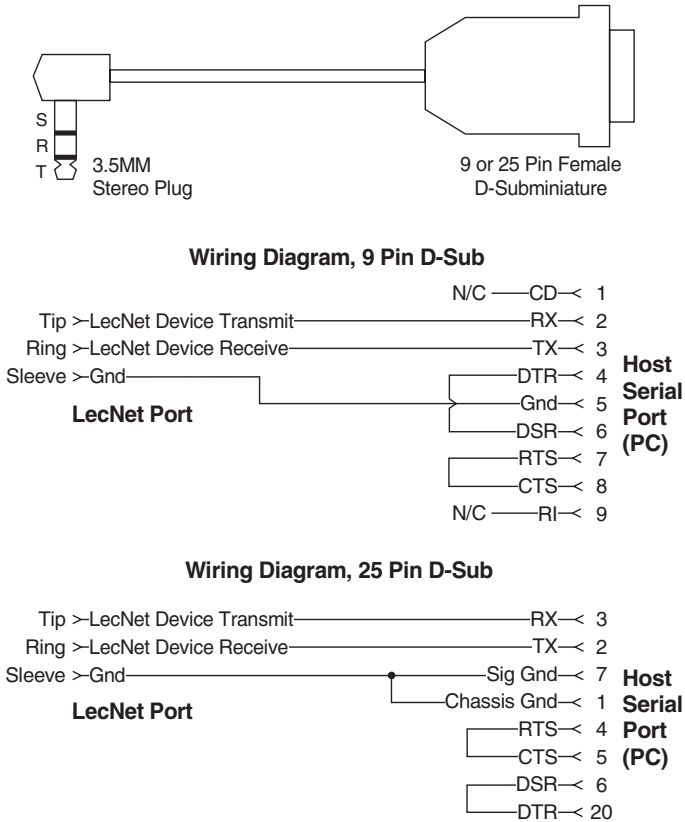

LecNet Device to AMX or Crestron

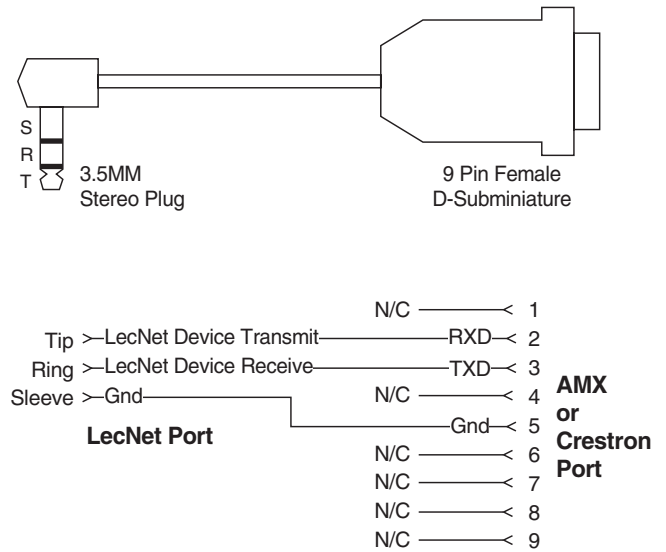

AMX Programming Notes

If you are using an AMX system to control your LecNet equipment, you'll want to purchase the Lectrosonics PT3 Protocol Translator. The PT3 connects between the AMX bus and any LecNet equipment. With the PT3, the LecNet equipment looks just like native AMX equipment. The PT3 is the fastest and most productive way to control LecNet devices with an AMX system.

SERIAL PORT COMMANDS AVAILABLE

All LecNet devices use a modification of the typical one-to-one connection between two RS-232 compatible devices. LecNet devices have both an RS-232 transmitter and receiver section. The transmitter section is “tri-stated”, or placed in a high impedance mode, until the particular device is addressed. To facilitate the simple parallel connection of multiple devices on a single RS-232 port, an addressing scheme is employed to route commands from the host to the proper LecNet device. When a device receives its address from the host computer, it temporarily turns on its RS-232 transmitter long enough to send whatever data is requested by the host. In this way, multiple devices may drive a single transmit signal back to the host, because only the addressed device will turn on its transmitter.

Valid address values are 128-254 (80 hex-FE hex). 255 (FF hex) is an invalid address and must not be used. Because a LecNet device will interpret any single data byte whose value is greater than 127 as an address, single byte data (as opposed to addresses) sent from the host must be in the range of 0-127. If a data value needs to be sent from the host that exceeds 127, the host must format two bytes of output such that the first byte is the lower 7 bits of the 8 bit value, and the second byte is 1 if the MSB of the data byte is 1, or 0 if the MSB of the data byte is 0.

All interchange of commands and data with any LecNet device should be done in hex rather than ASCII. The only exception to this is the return data on the Get Device Name command (see command description below).

Each LecNet command must be preceded by the address of the device to be controlled. If a device with the requested address exists on the system, it will respond by sending a 0 (0 hex, not ASCII) back to the host. Thus, each interchange with a LecNet device follows this pattern:

- 1) Host sends device address in hex (1 byte);
- 2) Host receives byte of 0 hex from the LecNet device as acknowledgment;
- 3) Host sends command (1 byte, hex) to the LecNet device;
- 4) Host and LecNet device exchange data based on particular command sent.

Note that some LecNet commands cause LecNet devices to return an additional acknowledgment byte of data to confirm the end of a transaction. This is most typical of commands that cause the LecNet device to be busy for more than a few milliseconds processing the command. The additional acknowledgment byte lets the host know that the LecNet device is no longer busy and can receive more commands. If a command does return an additional acknowledgment byte, this will be explicitly stated in the command description.

As an example of a specific interchange between a host and an AM8 the following general procedure would be used to get a name string back from an AM8:

Set up the communications parameters of the device which will be the host. The correct parameters for all LecNet devices are 9600 baud, no parity, 8 data bits, 1 stop bit. This must only be done once when the host is initialized.

- 1) Host sends device address. For a factory default AM8, this would be 128, or 80 hex (1 byte);
- 2) Host receives byte of 0 hex from the AM8 as acknowledgment;
- 3) Host sends command 1 hex (1 byte) to the AM8 to get the name data;
- 4) The LecNet device sends to the host 4 bytes. The first byte is 3 hex, which is the number of bytes in the AM8's name string. The AM8 will then send the ASCII characters “A”, “M”, and “8” to the host.

The following section is a listing of available commands grouped based on the AM8 function to which the commands are related. The word “Host” in the command descriptions means the IBM PC or compatible, AMX controller, or Crestron controller to which the AM8 is connected. Note that Lectrosonics supplies AMX include files for controlling all LecNet devices. These files are included on the LecNet Master Pro setup disks which ship with each LecNet device. The files are automatically installed on your system during the LecNet installation. If you use the default setup subdirectory of “c:\lecnet”, the AMX include files will be found in “c:\lecnet\amx”.

There are several “status” flags that may be set by the host computer. Those flag commands that store the new value in EEPROM will continue to have the new value even if the power to the AM8 is turned off. One of these flags is particularly important when controlling the AM8 from an AMX or Crestron controller. This is **Set Remote Level Read Flag**, command 7. This flag must be set to 1 (see the command description below for more information) before the AM8 will respond to any attempts to change the gain of any channel via the LecNet RS-232 port. When the Remote Level Read flag is set to 1, the AM8 will ignore any inputs on the rear panel DB-15 connector. Similarly, if the Remote Level Read flag is set to 0, the AM8 will ignore any remote level data sent via the LecNet RS-232 port. Two other commands, **Set Compressor/Leveller Read Switch Flag** and **Set Auto/Direct Read Flag** work in a similar manner to **Set Remote Level Read Flag**. The AM8 uses either the LecNet RS-232 data or the associated local switch to control the Compressor/Leveller functionality or the Auto/Direct status of the channels, depending on the state of these two flags.

The following commands are described from the perspective of the host. A “Get” command allows the host to receive information from the AM8. A “Set” command allows the host to send information to set some parameter in the AM8.

General Device Commands

Get Device Name - Causes the AM8 to send its “name” string back. The first data byte is the length of the name string, and the rest of the data bytes are the device name.

Host sends command - 1

Host receives data bytes: Byte 1 is the length of the name string (3 for the AM8), bytes 2, 3, and 4 are the ASCII values for “AM8” (66,77,56).

Set Device Address - Sets the AM8 device address and stores the new address in EEPROM.

Host sends command - 2

Host sends 1 byte: device address, valid range 128 to 254.

Get Firmware Version - Causes the AM8 to send to the host the version number of the current firmware. For example, Version 1.0 software would be returned as 10 (decimal).

Host sends command - 25 (19 hex)

Host receives data byte: firmware version.

Get Channel “On” Status - Causes the AM8 to send to the host the current status of all channels (i.e. “on” or “off”), packed into one data byte as shown below. The status of each channel is represented by one bit in the returned data byte:

MSB (Bit 7) - CH8 status

Bit 6 - CH7 status

Bit 5 - CH6 status

Bit 4 - CH5 status

Bit 3 - CH4 status

Bit 2 - CH3 status

Bit 1 - CH2 status

Bit 0 - CH1 status

If the associated bit is a 1, the channel is currently on, while a 0 indicates an off channel.

Host sends command - 20 (14 hex)

Host receives data byte: 0-255, interpreted according to the table above.

Channel Levels and Attenuation Commands

Get Channel Level - Causes the AM8 to send to the host channel levels, either singly or all eight. Range is from 0-255, where 0 corresponds to -65.33dBu, and 255 to +20dBu.

Host sends command - 3

Host sends 1 byte: a value 0-7 causes the AM8 to output the level of a single channel, 1-8. A value of 8 or greater outputs the level from all eight channels as eight consecutive data bytes.

Host receives 1 or 8 bytes: for the channel level(s).

Get Channel Attenuation - Causes the AM8 to send to the host channel attenuation, either singly or all eight.

Range is from 0-255, with each bit scaled to .33dB. The output channel attenuation number is the sum of the remote channel and remote main attenuation values, the attenuation from the automatic algorithm, and the attenuation from the compressor/leveller system (if used).

Host sends command - 4

Host sends 1 byte: a value 0-7 causes the AM8 to output the level of a single channel, 1-8. A value of 8 or greater outputs the level from all eight channels as eight consecutive data bytes.

Host receives 1 or 8 bytes: for the channel attenuation(s).

Remote Attenuation Commands

Set Remote Level Read Flag - Allows the host to set the value of the Remote Level Read Flag. If the flag is 0, the AM8 reads the 15 pin remote level port to determine the remote channel attenuation value. If the flag is set to 1, remote channel and main attenuation values used are those input from the serial port. The new flag value is stored in EEPROM.

Host sends command - 7

Host sends data byte: 0 or 1, where 0 = values from DB-15 port, 1 = values from RS-232

Get Remote Channel Attenuation - Causes the AM8 to send to the host remote channel attenuation, either singly or all eight. Range is from 0-255, with each bit scaled to .33dB. Note that this number represents the sum of the individual plus the main channel remote attenuation values. If the Remote Level Read Flag (see command 7 below) is 0, the values returned will be those from the DB-15 remote level port. If the Remote Level Read Flag is 1, the values returned will be those currently in memory.

Host sends command - 5

Host sends 1 byte: a value 0-7 causes the AM8 to output the remote attenuation value of a single channel, 1-8. A value of 8 or greater outputs the level from all eight channels as eight consecutive data bytes.

Host receives 1 or 8 bytes: for the remote channel attenuation(s).

Set Remote Attenuation Values - Allows the host to set the remote attenuation levels of the AM8. Valid input data is 0-31. 0-30 gives 0dB to 30dB attenuation. 31 is off. Note that the Remote Level Read flag must be set to 1 for this command to be valid (see "Set Remote Level Read Flag" command below).

Host sends command - 6

Host sends channel byte: 0-7 to signify which channel 1-8 to change.

Host sends data byte: 0-31 for attenuation value as outlined above.

Get Remote Main Attenuation - Causes the AM8 to send to the host remote main attenuation. Range is from 0-255, with each bit scaled to .33dB.

Host sends command - 29 (10 hex)

Host receives 1 byte: 0-255 for the remote main attenuation level.

Set Remote Main Attenuation - Allows the host to set the remote main attenuation level of the AM8. Valid input data is 0-31 (0-1F hex). 0-30 gives 0dB to 30dB attenuation. 31 is off. Note that the Remote Level Read flag must be set to 1 for this command to be valid (see "Set Remote Level Read Flag" command below).

Host sends command - 34 (22 hex)

Host sends data byte: 0-31 to program main attenuation value as outlined above.

Compressor/Leveller Commands

Set Compressor/Leveller Read Switch Flag - Allows the host to set the value of the Compressor/Leveller Read Switch Flag. If the flag is 0, the AM8 reads the internal compressor/leveller In/Out switch to determine whether the system should be active. If the flag is 1, the AM8 will use the value stored in EEPROM. The new value is stored in EEPROM.

Host sends command - 26 (1A hex)

Host sends data byte: 0 or 1, where 0 = read the internal In/Out switch, 1 = use stored value

Set Compressor/Leveller In/Out Status Flag - Allows the host to set the value of the Compressor/Leveller In/Out Status Flag. This flag is used to activate or deactivate the compressor/leveller system from the host. If the flag is 0, the compressor/leveller system is in. If the flag is 1, the system is out. The new status flag value is stored in EEPROM. This command is only active if the Compressor/Leveller Read Switch Flag is 1 (see “Set Compressor/Leveller Read Switch Flag” command above).

Host sends command - 24 (18 hex)

Host sends data byte: 0 or 1, where 0 = C/L system active, 1 = C/L system inactive.

Set the Compressor/Leveller Threshold - Causes the AM8 to send to the host the current threshold value for the compressor/leveller. The threshold value ranges from 0 to 127, corresponding to -42.33dBu to 0dB threshold values.

Host sends command - 8

Host receives 1 byte: 0-127 (0-7F hex), corresponding to -42.33dBu to 0dBu

Get Compressor/Leveller Threshold - Allows the host to set a value for the compressor/leveller threshold to be stored in EEPROM. Input range is 0-127, which corresponds to -42.33dB to 0dB threshold. This command is only available when the Threshold Read Flag is set to 1 (see “Set Compressor/Leveller Threshold Read Flag” command below).

Host sends command - 9

Host sends data byte: 0-127 (0-7F hex), corresponding to -42.33dBu to 0dBu threshold.

Set Compressor/Leveller Threshold Read Flag - Allows the host to set the value of the Threshold Read Flag. If the flag is 0, the internal threshold pot is used to establish the threshold. If the flag is 1, the stored compressor/leveller threshold value is used (see “Input Compressor/Leveller Threshold” command above).

Host sends command - 10 (0A hex)

Host sends data byte: 0 or 1, where 0 = values from internal threshold pot, 1 = use stored value.

Get Current Compressor/Leveller Attenuation - Causes the AM8 to send to the host the current value of attenuation associated with the compressor/leveller system. The range will be 0-60, which corresponds to 0dB to 20dB of attenuation.

Host sends command - 23 (17 hex)

Host sends data byte: 0-60 (0-3C hex), corresponding to 0dB to 20dB attenuation.

Get Compressor/Leveller Status - Causes the AM8 to send to the host the current status (active or inactive) of the compressor/leveller system. A returned value of 0 indicates that the system is active, while a returned value of 1 indicates that the system is inactive.

Host sends command - 30 (1E hex)

Host sends data byte: 0 = system active, 1 = system inactive.

Auto/Direct Mode Commands

Set Auto/Direct Read Flag - Allows the host to change the value of the Direct/Auto Read Flag. If the flag is 0, the AM8 reads the internal Direct/Auto switches to determine the channel status. If the flag is set to 1, the value stored in EEPROM is used. The new flag value is stored in EEPROM.

Host sends command - 15 (0F hex)

Host sends data byte: 0 or 1, where 0 = read internal switches, 1 = use stored value.

Get Auto/Direct Mode - Causes the AM8 to send to the host the a data byte which indicates the current mode of all channels, packed into one data byte as shown below. The mode of each channel is represented by one bit in the returned data byte as shown below:

MSB (bit 7) - CH8 mode

Bit 6 - CH7 mode

Bit 5 - CH6 mode

Bit 4 - CH5 mode

Bit 3 - CH4 mode

Bit 2 - CH3 mode

Bit 1 - CH2 mode

Bit 0 - CH1 mode

If the associated bit is a 1, the channel is in Direct mode, while a 0 is Auto mode.

Host sends command - 13 0D hex)

Host receives data byte: 0-255 (0-FF hex), interpreted according to the table above.

Set Auto/Direct Mode - Allows the host to input a new value for the Direct/Auto status variable. The data byte sent by the host should be assembled according to the table above ("Output Auto/Direct Mode" command). A "1" in a bit position will put the associated channel in the Direct mode, while a "0" will put the associated channel in the Auto mode. The Auto/Direct Read Flag must be set to 1 for this command to be valid (see "Set Auto/Direct Read Flag" command below).

Host sends command - 14 (0E hex)

Host sends 2 data bytes: Byte 1 is the low 7 bits of the mode data (defined as in the table above). Byte 2 is 1 if the MSB of the mode data is 1, and 0 if the MSB of the mode data is 0.

LIMITED ONE YEAR WARRANTY

The equipment is warranted for one year from date of purchase against defects in materials or workmanship provided it was purchased from an authorized dealer. This warranty does not cover equipment which has been abused or damaged by careless handling or shipping. This warranty does not apply to used or demonstrator equipment.

Should any defect develop, Lectrosonics, Inc. will, at our option, repair or replace any defective parts without charge for either parts or labor. If Lectrosonics, Inc. cannot correct the defect in your equipment, it will be replaced at no charge with a similar new item. Lectrosonics, Inc. will pay for the cost of returning your equipment to you.

This warranty applies only to items returned to Lectrosonics, Inc. or an authorized dealer, shipping costs prepaid, within one year from the date of purchase.

This Limited Warranty is governed by the laws of the State of New Mexico. It states the entire liability of Lectrosonics Inc. and the entire remedy of the purchaser for any breach of warranty as outlined above. NEITHER LECTROSONICS, INC. NOR ANYONE INVOLVED IN THE PRODUCTION OR DELIVERY OF THE EQUIPMENT SHALL BE LIABLE FOR ANY INDIRECT, SPECIAL, PUNITIVE, CONSEQUENTIAL, OR INCIDENTAL DAMAGES ARISING OUT OF THE USE OR INABILITY TO USE THIS EQUIPMENT EVEN IF LECTROSONICS, INC. HAS BEEN ADVISED OF THE POSSIBILITY OF SUCH DAMAGES. IN NO EVENT SHALL THE LIABILITY OF LECTROSONICS, INC. EXCEED THE PURCHASE PRICE OF ANY DEFECTIVE EQUIPMENT.

This warranty gives you specific legal rights. You may have additional legal rights which vary from state to state.

LECTROSONICS, INC.

581 LASER ROAD
RIO RANCHO, NM 87124 USA

November 1, 2001